

## **Microcontroller system of the air temperature sensor**

*Development of a temperature control system based on the ATmega32 microcontroller is provided. A description of the algorithm of the device action and the result of the research work are provided.*

### **Description and specifications of the microcontroller ATmega 32**

Atmega32/L is a CMOS 8-bit microcontroller that is built on the advanced AVR RISC architecture. It uses commands that are executed in one machine cycle. The controller has productivity close to 1 MIPS at a frequency of 1 MHz. This allows us to effectively optimize energy consumption by choosing the optimal productivity.

The AVR core combines an extended instruction set with 32 general-purpose operating registers. All 32 registers are connected to the arithmetic logic unit, which provides access to two independent registers for the execution time of the command in one machine cycle. Thanks to the chosen architecture, it achieves the highest code speed and, accordingly, high productivity, exceeding the speed of the corresponding CISC microcontroller by 10 times.

ATmega32/L contains 32 Kbyte of internal system programmable FLASH memory, which allows reading while writing, 1024 bytes of EEPROM, 2 Kbyte of SRAM, 32 working registers, JTAG interface for scanning internal registers, embedded debugging and programming system, three flexible timers, internal and external interrupts, programmable serial interface USART, byte-oriented two-wire serial interface, 8-channel 10-bit ADC with differential programmable amplifier (TQFP only), programmable timer with the internal generator.

The combination of advanced 8-bit RISC CPU architecture and solid-state FLASH memory provides Atmega32 with high flexibility and cost-effectiveness in embedded control systems.

### **Description of the device operation algorithm**

When the system is turned on, all components are initialized. Further in the cycle the sensor is interrogated. If it is not detected, then the error flag is set and the corresponding inscription has appeared on the display. If it is found the cycle continues. Then the result is formed and displayed. And the cycle repeats itself (Figure 1).

### **System modeling**

For system simulation, we use the integrated environment Proteus for the development of electronic devices on microcontroller bases.

After writing the code in the compiler and saving it, we write it in the memory of the microcontroller programs.

The simulation result can be seen in Figure 2 and Figure 3.

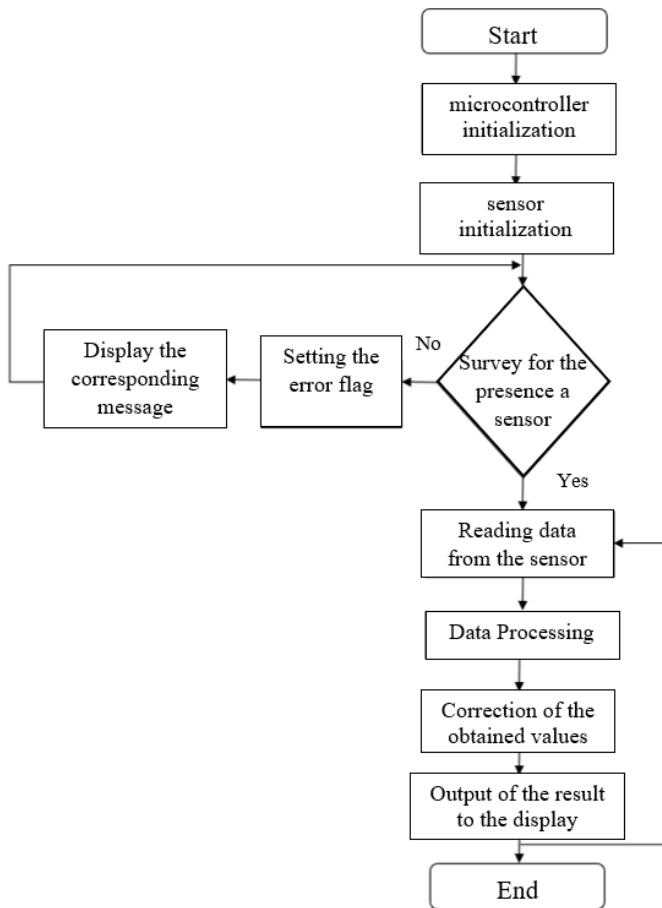

Fig. 1. Chart of the device operation algorithm

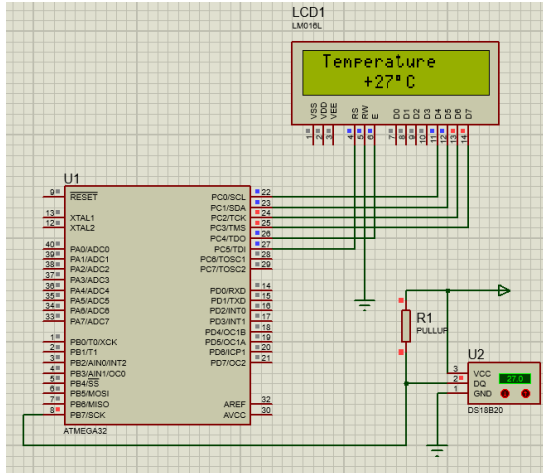

Fig. 2. The circuit modeling with a connected sensor

If you turn off the sensor, a corresponding message will appear on the display.

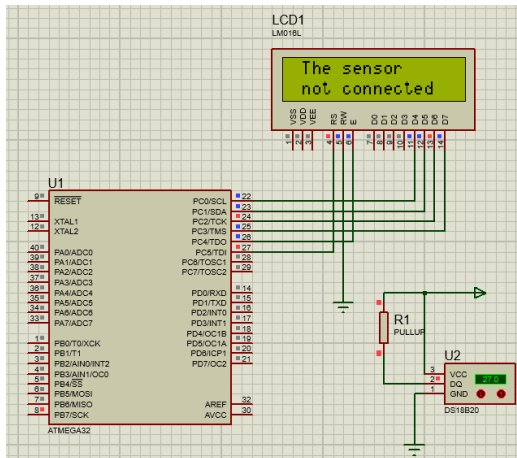

Fig. 3. The circuit modeling with a disabled sensor

## References

1. ATMEGA32 Datasheet (PDF) - ATMEL Corporation <https://www.alldatasheet.com/datasheet-pdf/pdf/77378/ATMEL/ATMEGA32.html>